

JVC

SERVICE MANUAL

CORDLESS STEREO HEADPHONES

HA-W250RF (J)



Contents

Specifications.....	Front cover
1. Operating Manual.....	3
2. Disassembly.....	12
3. Schematic Diagram.....	13
4. Print Circuit Board.....	14
5. Measurement Condition.....	14
6. Wiring Diagram.....	16
7. Block View Inside IC.....	16
8. Block Diagram.....	17
9. Electric Parts List.....	17
10. Exploded view.....	18
11. Mechanical Parts List.....	18
12. Packing Method.....	19
13. Packing Materials.....	19
14. Accessories List.....	19

Specifications

General Specifications

System	: Radio Frequency (UHF stereo)
Modulation	: Frequency modulation
Carrier frequency	: 911.35- 913.65 MHz
Usable area (distance to reach)	: Approx. 100m (328 ft) : using JVC measurements systems
Frequency response	: 28-17,000 Hz
Distortion	: Less than 4 % (at 1 kHz)

Transmitter (J21967-001)

Power requirements	: DC 12 V (with the exclusive AC adaptor J46598-001)
Audio input terminal	: 3.5 mm dia. stereo miniplug
Input impedance	: 30 k Ω
Reference input level	: 350 mV
Dimensions	: 137(W) x 147(D) x 123(H) mm (5-7/16" x 5-13/16" x 4-7/8") (Including antenna)
Mass	: 200 g (7.1 oz) (Without connection cord and AC adaptor)

Headphones (HA-W250RF)

Power requirements	: Rechargeable Ni-Cd battery (1.2 V) x 2
Battery running time	: 6 hours (When charged for 24 hours)
Mass	: 220 g (7.7 oz) (With provided rechargeable Ni-Cd battery x 2)

Provided Accessories

Instructions	x 1
AC adaptor	x 1
Connection cord	x 1 (3.5 mm dia. stereo minijack- RCA pin plug x 2 : 0.1 m (0.3 ft))
Plug adaptor	x 1 (converts 3.5 mm dia. stereo miniplug to a 6.3 mm dia. standard stereo phone plug)
Exclusive rechargeable Ni-Cd battery	x 2

This product has Auto-tuning function.

On noisy frequency part, the receiver in headphone starts searching the transmitted frequency and stop tuning on the frequency.

In the condition of disturbing frequencies and / or in the place at a distance from transmitter, auto-tuning function could start searching by potential noise and it causes sound breaks.

* Design and specifications subject to change without notice.

Safety Precautions

1. This design of this product contains special hardware and many circuits and components specially for safety purposes. For continued protection, no changes should be made to the original design unless authorized in writing by the manufacturer. Replacement parts must be identical to those used in the original circuits. Services should be performed by qualified personnel only.
2. Alterations of the design or circuitry of the product should not be made. Any design alterations of the product should not be made. Any design alterations or additions will void the manufacturer's warranty and will further relieve the manufacture of responsibility for personal injury or property damage resulting therefrom.
3. Many electrical and mechanical parts in the products have special safety-related characteristics. These characteristics are often not evident from visual inspection nor can the protection afforded by them necessarily be obtained by using replacement components rated for higher voltage, wattage, etc. Replacement parts which have these special safety characteristics are identified in the Parts List of Service Manual. Electrical components having such features are identified by shading on the schematics and by (\triangle) on the Parts List in the Service Manual. The use of a substitute replacement which does not have the same safety characteristics as the recommended replacement parts shown in the Parts List of Service Manual may create shock, fire, or other hazards.
4. The leads in the products are routed and dressed with ties, clamps, tubings, barriers and the like to be separated from live parts, high temperature parts, moving parts and/or sharp edges for the prevention of electric shock and fire hazard. When service is required, the original lead routing and dress should be observed, and it should be confirmed that they have been returned to normal, after re-assembling.

5. Leakage current check (Electrical shock hazard testing)

After re-assembling the product, always perform an isolation check on the exposed metal parts of the product (antenna terminals, knobs, metal cabinet, screw heads, headphone jack, control shafts, etc.) to be sure the product is safe to operate without danger of electrical shock. Do not use a line isolation transformer during this check.

- Plug the AC line cord directly into the AC outlet. Using a "Leakage Current Tester", measure the leakage current from each exposed metal parts of the cabinet, particularly any exposed metal part having a return path to the chassis, to a known good earth ground. Any leakage current must not exceed 0.5mA AC (r.m.s.)

- Alternate check method

Plug the AC line cord directly into the AC outlet. Use an AC voltmeter having, 1,000 ohms per volt or more sensitivity in the following manner. Connect a 1,500 Ω 10W resistor paralleled by a 0.15 μ F AC-type capacitor between an exposed metal part and a known good earth ground.

Measure the AC voltage across the resistor with the AC voltmeter.

Move the resistor connection to each exposed metal part, particularly any exposed metal part having a return path to the chassis, and measure the AC voltage across the resistor. Now, reverse the plug in the AC outlet and repeat each measurement. voltage measured Any must not exceed 0.75 V AC (r.m.s.). This corresponds to 0.5 mA AC (r.m.s.).

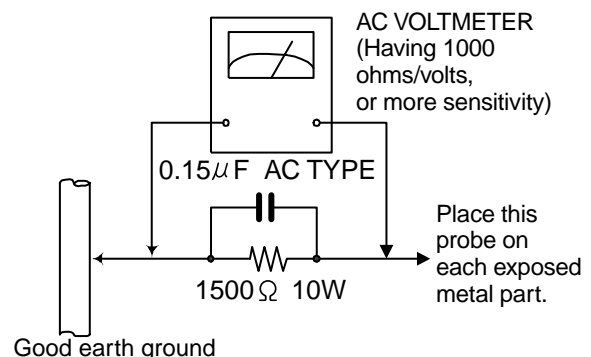

Warning

1. This equipment has been designed and manufactured to meet international safety standards.
2. It is the legal responsibility of the repairer to ensure that these safety standards are maintained.
3. Repairs must be made in accordance with the relevant safety standards.
4. It is essential that safety critical components are replaced by approved parts.
5. If mains voltage selector is provided, check setting for local voltage.

JVC

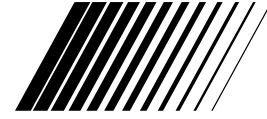

HA-W250RF (J)

CORDLESS STEREO HEADPHONES
CASQUE STEREO SANS FIL
AURICULARES ESTEREO INALAMBRICOS

CORDLESS STEREO HEADPHONES

HA-W250RF (J)



For Customer Use:
Enter below the Model No. and Serial No.
which is located on the bottom of cabinet.
Retain this information for future reference.

Model No. _____
Serial No. _____

INSTRUCTIONS
MANUEL D'INSTRUCTIONS
MANUAL DE INSTRUCCIONES

JVC
VICTOR COMPANY OF JAPAN, LIMITED

Printed in China
J5500-100A

J5500-100A

HA-W250RF (J)

Hearing Comfort and Well-Being

- Do not play your headphones at a high volume. Hearing experts advise against continuous extended play.
- If you experience a ringing in your ears, reduce volume or discontinue use.

Traffic Safety

- Do not use while operating a motorized vehicle. It may create a traffic hazard and is illegal in many areas.
- You should use extreme caution or temporarily discontinue use in potentially hazardous situations.
- Even though your headphones are of the open-air type designed to let you hear outside sounds, don't turn up the volume so high that you can't hear what's around you.

FCC INFORMATION

This device complies with Part 15 of the FCC Rules. Operation is subject to the following two conditions:

- (1) This device may not cause harmful interference.
- (2) This device must accept any interference received, including interference that may cause undesired operation.

CAUTION — Changes or modifications not approved by JVC could void user's authority to operate the equipment.

Contact

Address: JVC AMERICAS CORP.
JVC COMPANY OF AMERICA
1700 Valley Road Wayne, N.J. 07470

Telephone: (973) 315-5000

Note: This equipment has been tested and found to comply with the limits for a Class B digital device, pursuant to Part 15 of the FCC rules. These limits are designed to provide reasonable protection against harmful interference in a residential installation. This equipment generates, uses and can radiate radio frequency energy and, if not installed and used in accordance with the instructions, it may cause harmful interference to radio communications. However, there is no guarantee that interference will not occur in a particular installation. If this equipment does cause harmful interference to radio or television reception, which can be determined by turning the equipment off and on, the user is encouraged to try to correct the interference by one or more of the following measures:

- Reorient or relocate the receiving antenna.
- Increase the separation between the equipment and receiver.
- Connect the equipment into an outlet on a circuit different from that to which the receiver is connected.
- Consult the dealer or an experienced radio/TV technician for help.

WARNING:

TO REDUCE THE RISK OF FIRE OR ELECTRIC SHOCK, DO NOT EXPOSE THIS APPLIANCE TO RAIN OR MOISTURE.

CAUTION:

CHARGE ONLY WITH PROVIDED NICKEL-CADMIUM TYPE BATTERIES. OTHER TYPES OF BATTERIES MAY BURST CAUSING PERSONAL INJURY AND DAMAGE.

AVERTISSEMENT:

POUR RÉDUIRE LES RISQUES D'INCENDIE OU DE CHOC ÉLECTRIQUE, NE PAS EXPOSER CET APPAREIL À LA PLUIE NI À L'HUMIDITÉ.

ATTENTION:

NE RECHARGER QU'AVEC DES BATTERIES DE TYPE CADMIUM-NICKEL FOURNI. D'AUTRES TYPES DE BATTERIES POURRAIENT ÉCLATER CAUSANT DES BLESSURES ET DES DOMMAGES.

IMPORTANT**CAUTION:**

TO PREVENT ELECTRIC SHOCK DO NOT USE THIS PLUG WITH AN EXTENSION CORD, RECEPTACLE OR OTHER OUTLET UNLESS THE BLADES CAN BE FULLY INSERTED TO PREVENT BLADE EXPOSURE.

ATTENTION:

POUR PREVENIR LES CHOCS ELECTRIQUES NE PAS UTILISER CETTE FICHE AVEC UN PROLONGATEUR, UNE PRISE DE COURANT OU UNE AUTRE SORTIE DE COURANT, SAUF SI LES LAMES PEUVENT ETRE INSEREES A FOND SANS EN LAISSER AUCUNE PARTIE A DECOUVERT.

- (1) This device may not cause interference.
- (2) This device must accept any interference, including interference that may cause undesired operation of the device.

- (1) Ce produit ne cause pas d'interférence.
- (2) Ce produit doit accepter toute interférence, incluant interférence qui peut causé opération non désiré.

“SOME DO’S AND DON’TS ON THE SAFE USE OF EQUIPMENT”

This equipment has been designed and manufactured to meet international safety standards but, like any electrical apparatus, care must be taken if you are to obtain the best results and safety is to be assured.



- Do** read the operating instructions before you attempt to use the equipment.
- Do** ensure that all electrical connections (including the plug, extension cord and inter-connections between pieces of equipment) are properly made and in accordance with the manufacturer’s instructions. Switch off and withdraw the plug when making or changing connections.
- Do** consult your dealer if you are ever in doubt about the installation or operation or safety of your equipment.
- Do** be careful with glass panels or doors on equipment.



- DON’T** continue to operate the equipment if you are in any doubt about it working normally, or if it is damaged in any way—switch off—withdraw the plug and consult your dealer.
- DON’T** remove any fixed cover as this may expose dangerous voltages.
- DON’T** leave equipment switched on when it is unattended unless it is specifically stated that it is designed for unattended operation or has a standby mode. Switch off using the switch on the equipment and make sure that your family know how to do this. Special arrangements may need to be made for infirm or handicapped people.
- DON’T** use equipment such as personal stereos or radios so that you are distracted from the requirements of road safety. It is illegal to watch television when driving.
- DON’T** listen to headphones at high volume as such use can permanently damage your hearing.
- DON’T** obstruct the ventilation of the equipment, for example with curtains or on soft furnishings. Overheating will cause damage and shorten the life of the equipment.
- DON’T** use makeshift stands and NEVER fix legs with wood screws. To ensure complete safety always fit the manufacturer’s approved stand or legs with the fixing screws supplied according to the instructions.
- DON’T** allow electrical equipment to be exposed to rain or moisture.

ABOVE ALL

NEVER let anyone especially children push anything into holes, slots or any other opening in the case. This could result in a fatal electrical shock.
NEVER guess or make changes with electrical equipment of any kind. It is better to be safe than sorry!

Thank you for purchasing this JVC product.
Before you begin operating this unit, please read the instructions carefully to be sure you get the best possible performance.
If you have any questions, consult your JVC dealer.
ENGLISH INSTRUCTIONS Page 6 – 17

Nous vous félicitons d'avoir acquis ce produit JVC.
Avant de vous en servir, lisez attentivement le mode d'emploi pour en obtenir les meilleures performances.
Si vous avez d'autres questions, interrogez votre revendeur JVC.
INSTRUCTIONS EN FRANÇAIS Page 18 – 29

Gracias por adquirir este producto JVC.
Antes de utilizar la unidad, lea cuidadosamente estas instrucciones para obtener el máximo rendimiento.
Si tiene cualquier duda, póngase en contacto con su distribuidor de productos JVC.
INSTRUCCIONES EN ESPAÑOL Página 30 – 41

ENGLISH

FRANÇAIS

ESPAÑOL

	CAUTION RISK OF ELECTRIC SHOCK DO NOT OPEN	
<p>CAUTION: TO REDUCE THE RISK OF ELECTRIC SHOCK. DO NOT REMOVE COVER (OR BACK). NO USER-SERVICEABLE PARTS INSIDE. REFER SERVICING TO QUALIFIED SERVICE PERSONNEL.</p>		

 The lightning flash with arrowhead symbol, within an equilateral triangle, is intended to alert the user to the presence of uninsulated "dangerous voltage" within the product's enclosure that may be of sufficient magnitude to constitute a risk of electric shock to persons.

 The exclamation point within an equilateral triangle is intended to alert the user to the presence of important operating and maintenance (servicing) instructions in the literature accompanying the appliance.

HA-W250RF (J)

CAUTION

To reduce the risk of electrical shocks, fire, etc.:

1. Do not remove screws, cover or cabinet.
2. Do not expose this appliance to rain or moisture.

IMPORTANT**1. Installation**

- Select a place which is level, dry and neither too hot nor too cold (between 0°C and 35°C /32°F and 95°F).
- Keep away from direct sunlight.
- Do not put it too close to a heater.

2. Power cord

- Do not handle the power cord with wet hands!
- Do not bend the power cord sharply.

3. Malfunctions, etc.

- There are no serviceable parts inside. If anything goes wrong, unplug the power cord and consult your dealer.
- Do not insert any metallic object.
- Do not allow water to get inside.

FEATURES

- Frequency modulation system which allows headphones to be used even in areas where the transmitter cannot be seen
- Reception range (up to 328 ft (100 m): using JVC measurement system)
- Auto Tuning Function: Lock in the signal at the touch of a button
- Foldable and compact design
- Easy-to-handle light body
- Rechargeable system with Ni-Cd batteries provided
- Large 40 mm dia. drivers for high-quality sound
- Automatic Power On/Off transmitter.
- Auto-level control circuit that automatically adjusts signals to the appropriate modulation level
- Single volume control adjusts the volume level of the left and right channels simultaneously
- Adaptable to any audio/visual equipment

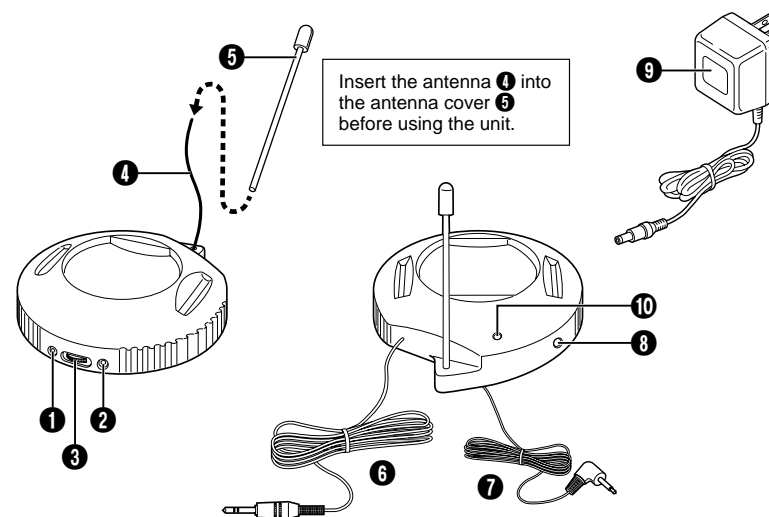
NAMES OF PARTS AND THEIR FUNCTIONS**Transmitter****1 POWER (Indicator)**

When an audio signal is input : The power automatically turns on and the indicator lights in green.

2 CHARGE (Indicator)

The indicator lights in red while the battery is being charged.

3 TUNING (Tuning control)

Adjusts the transmission frequency.

4 ANTENNA**5 ANTENNA COVER**

Cover the antenna 4 before using the unit.

6 Audio input cord and plug

2m cord and 3.5mm dia. stereo miniplug

7 Charging output cord and plug**8 DC IN (DC 12 V jack)****9 AC adaptor (J46598-001)**

Connects to a household AC outlet (AC 120 V, 60 Hz).

Note :

The provided AC adaptor is exclusively for use with this unit.

Do not connect to any other equipment.

10 Plug rest hole

While not in use, charging output cord and plug 7 can be inserted into this hole.

NAMES OF PARTS AND THEIR FUNCTIONS

Receiver (Cordless Headphones)

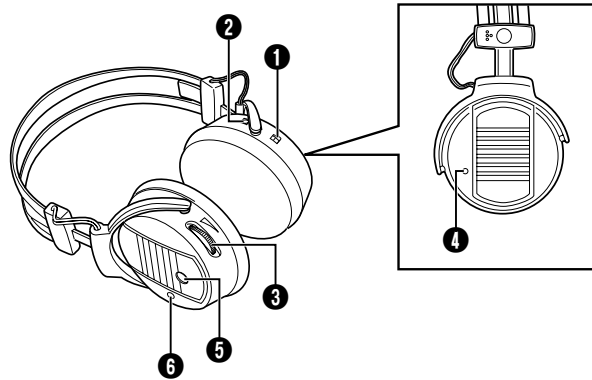

- 1 ON/OFF (Power switch)**
- 2 Charging input terminal**
- 3 VOL. (Volume control)**
Adjusts the volume level of the left and right channels simultaneously.
- 4 POWER (Indicator)**
The indicator lights in red when the power is turned on.
- 5 AUTO TUNING SWITCH (Tuning control)**
Adjusts the reception frequency. When the button is pressed, frequency tuning starts automatically and it stops when a signal is detected.

Note :
Signals not originating from the transmitter or unexpected signals can also cause the frequency tuning to stop. If this happens, press the button again to resume tuning.

- 6 STEREO (Indicator)**
The indicator lights in green when receiving the signal from the transmitter.
- Note :**
The indicator also lights in green with signals not originating from the transmitter.

CONNECTION

■ How to connect to AV equipment

Connection to HEADPHONES jack

When connecting to a standard stereo phone jack (6.3 mm dia.)
— Use the provided plug adaptor (Converts a stereo miniplug to a standard stereo phone plug)

To HEADPHONES jack

TV, audio amplifier, VCR, tape deck, video disc player, etc.

When connecting to a stereo minijack

When connecting to a monaural minijack
— Use an optional plug adaptor (Converts a stereo miniplug to a monaural miniplug)

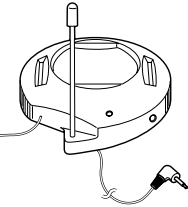

Connection to LINE OUT or REC OUT terminals

To LINE OUT or REC OUT terminals

TV, audio amplifier, VCR, tape deck, video disc player, etc.

R-channel (red plug)

L-channel (white plug)

Provided connection cord

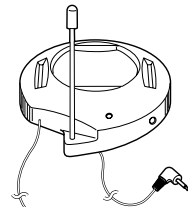

CONNECTION

Connection to power supply

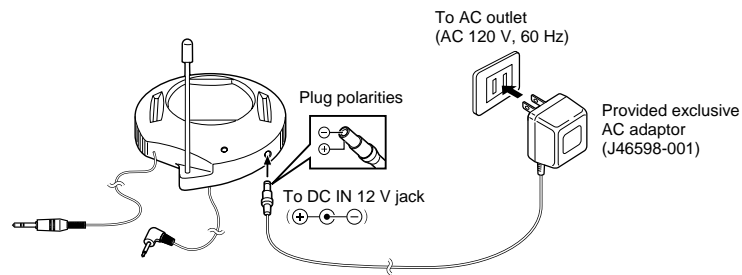

Note:

Be sure to use the provided exclusive AC adaptor (J46598-001) for connection. Use of any other AC adaptor may cause a malfunction.

RANGE OF USE

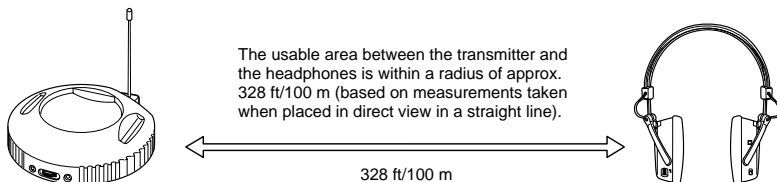

Note:

The usable area may differ depending on building structure, etc.
The range becomes shorter in the following cases:

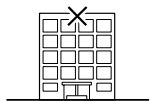

In places such as inside an apartment with reinforced concrete walls, or when the transmitter and headphones are separated by obstacles such as steel-reinforced doors.

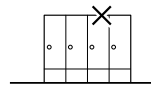

When items such as metal furniture are situated nearby.

- Be sure to keep this unit more than 1.64 ft/0.5 m away from concrete walls, metal furniture, etc.

POWER REQUIREMENTS OF HEADPHONES

Use two exclusive rechargeable Ni-Cd batteries to power the headphones. When you purchase this unit, be sure to charge the provided rechargeable Ni-Cd batteries according to the following procedures before use.

1. Insert the rechargeable Ni-Cd batteries

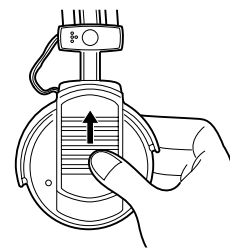

- ① Remove the battery compartment cover on the right side of headphones.

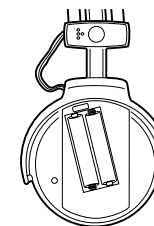

- ② Insert the two rechargeable Ni-Cd batteries with the polarities correctly positioned.

Cautions about the rechargeable batteries

If the batteries are used incorrectly, they may leak, heat or explode, and may cause fire, injury or soiling. Make note of the following:

1. Be sure to use the provided exclusive Ni-Cd batteries. Do not use any other rechargeable Ni-Cd battery or dry cell battery.
2. Insert batteries with the (+) and (-) polarities correctly positioned, following the indications on the equipment.
3. Do not use a new battery with an old one, and do not use batteries holding different amounts of charge together.
4. Do not throw batteries in a fire or heat them.
5. Do not short-circuit the positive (+) and negative (-) terminals. Also, do not carry or store them with small metallic objects such as necklaces or coins.
6. Do not deform, take apart, modify or directly solder the batteries.
7. Do not remove or damage the covering tube.
8. If you notice phenomena that has never happened before, such as leakage, color change or deformity, stop using the batteries.
9. If any liquid from the batteries gets into your eyes, it may cause blindness. If battery liquid does get into your eyes, do not rub them, but instead immediately wash them thoroughly with clean water, then consult a doctor at once. Also, should any liquid from the rechargeable batteries get onto your skin or clothes, it may burn your skin. In this case, wash with clean water immediately.
10. Do not immerse or wet the batteries in water.
11. Do not use or leave the batteries in an area where the temperature becomes significantly higher, such as in direct sunlight, inside a car on a hot day or near heat-generating equipment.
12. Do not subject the batteries to strong shocks or throw them.
13. Be sure to read the cautions on the batteries.

Please consult your JVC dealer when exchanging the batteries.

POWER REQUIREMENTS OF HEADPHONES

2. Charging rechargeable Ni-Cd batteries

- ❶ Set the ON/OFF (power) switch on the headphones to OFF.
The batteries cannot be charged when the switch is set to ON.
- ❷ Connect the charging output cord from the transmitter to the headphones.
- ❸ Connect the AC adaptor to the transmitter.
- ❹ Plug the AC adaptor into an AC outlet. The charger starts charging the batteries automatically and the transmitter's indicator lights in red.

Charging time

The battery can be fully charged in approx. 24 hours.

Battery running time

After charging is complete, you can use them continuously for approx. 6 hours.

Tips for better use

- Be sure to charge the batteries within the temperature range of 10° C ~ 35° C (50 °F ~ 95 °F).
- Charging batteries that are not completely exhausted will cause efficiency to decline. Be sure to charge them after they have been completely exhausted.

CAUTIONS ABOUT CHARGING

1. Be sure to use only this unit for charging.
2. You can charge the rechargeable Ni-Cd batteries approx. 300 times.
3. Charging times differ depending on the temperature range or the amount of charge already in the batteries.
4. Excessive charging doesn't result in malfunction.
5. Battery life will decrease in cold places.
6. If the usable time of fully-charged batteries decreases by about half, replace them with new ones. When purchasing rechargeable Ni-Cd batteries, consult the dealer from whom you bought this product.

Exclusive Rechargeable Ni-Cd Batteries :
J46863-001 (1.2 V, 240 mAh, 2 pcs/pack)

7. Though the rechargeable batteries may become hot after they have been charged or used, this is not malfunction.
8. Due to characteristics of the batteries, they expend their charge a little even when the power is turned off.

CAUTIONS ABOUT THE RECHARGEABLE BATTERY

ATTENTION:

The product that you have purchased contains a rechargeable battery. The battery is recyclable. At the end of its useful life, under various state and local laws, it may be illegal to dispose of this battery into the municipal waste stream. Check with your local solid waste officials for details in your area for recycling options or proper disposal.

HOW TO USE

1. Connect the transmitter and AV equipment. (Refer to page 9)
2. Connect the AC adaptor to the transmitter, then plug the AC adaptor into an AC outlet. (Refer to page 10)
3. Turn on the power on the transmitter and the connected AV equipment.

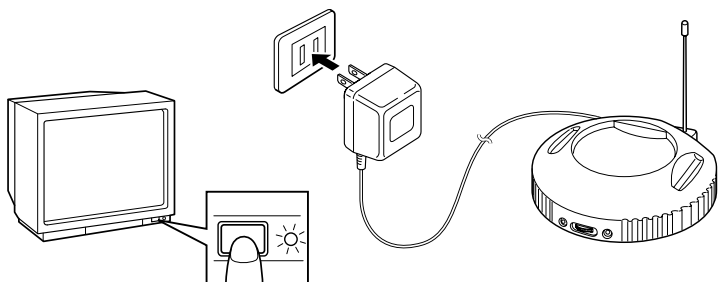

Transmitter power

When an audio signal is input, the transmitter's power is turned on automatically, and the indicator lights in green. Also, when no audio signal is input for about a minute, the indicator goes out automatically and the power turns off. (Automatic Power On/Off function)

In some situations, the power may not be turned on automatically by the input sound (e.g. a song with a quiet opening or gradual fade-in). This is not a malfunction.

4. Turn on the headphones' power. To avoid excessive volume, first set the headphones' volume to a low level.

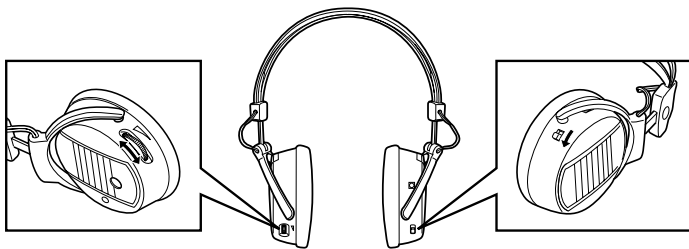

Before using the headphones for the first time, charge the rechargeable Ni-Cd battery.

HOW TO USE

5. Adjust the volume control of the connected AV equipment and the headphones, and set them to the desired listening level.
6. Push the AUTO TUNING switch control to get the best reception in the headphones.
When the button is pressed, frequency tuning starts automatically and it stops when a signal is detected.

Note :

Signals not originating from the transmitter or unexpected signals can also cause the frequency tuning to stop. If this happens, press the button again to resume tuning.

In cases of interference or too much noise, turn the TUNING control on the transmitter to another position, then repeat step 6.

To set optimum signal reception, adjustments should be done within a range of approx. 7 m/23 ft between the transmitter and the headphones.

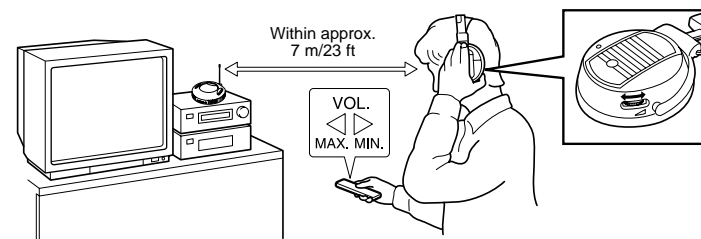

Tips for better use

For improved sound quality, set the volume level of the connected equipment as high as possible without causing distortion, while setting the volume level of the headphones to a slightly lower level.

After use

Keep the headphones' power off.

Notes:

1. When using the headphones, don't raise the volume excessively. Continuous listening for a long time at high volumes may damage your hearing.
2. For safety reasons, do not use the headphones while riding a bicycle or driving a motorcycle, car, etc.

TROUBLESHOOTING

What appears to be a malfunction may not always be serious. First make sure...

Symptoms	Cause	Remedy
No sound.	Is the transmitter's power OFF?	Check the connection of the transmitter. Turn the power on the connected AV equipment ON and start playing.
	Is the headphones' power OFF?	Turn on the headphones' power. (The indicator lights.)
	Is the battery in the headphones exhausted?	Fully charge the headphones.
	Is the volume of the headphones set to the minimum level?	Adjust the volume of the headphones to the appropriate level.
	Is the volume of the connected AV equipment set to the minimum level?	Raise the volume level of the connected AV equipment as high as possible without causing distortion.
No sound from the R-channel.	Is the transmitter connected to equipment with monaural audio output?	Connect them with an optional plug adaptor. (Converts monaural audio output to stereo audio output.)
Distorted sound.	Is the battery in the headphones exhausted?	Fully charge the headphones.
	Is the volume of the connected AV equipment set too high?	Adjust the volume level of the connected AV equipment as high as possible without causing distortion.
Noisy sound.	Is the battery in the headphones exhausted?	Fully charge the headphones.
	Are the frequency modulation signals being received correctly?	Push the AUTO TUNING switch on the headphones or turn the TUNING controls on the transmitter to adjust them until the headphones' indicator lights in green.
	Is the volume of the connected AV equipment set too low?	Adjust the volume level of the connected AV equipment as high as possible without causing distortion.
	Are the headphones too far away from the transmitter?	Use them within the range the frequency modulation signal can reach. (Refer to page 10.)
Battery charging is impossible.	Has the rechargeable Ni-Cd battery expired?	Replace it with a new Ni-Cd battery. Please consult your dealer for replacement.

SPECIFICATIONS

General Specifications

Modulation system	: Stereo frequency modulation system
Carrier frequency	: 911.35 – 913.65 MHz
Usable area (distance to reach)	: Approx. 328 ft (100 m) (using JVC measurement systems)
Frequency response	: 28 –17,000 Hz
Distortion	: Less than 4% (at 1 kHz)

Transmitter (J21967-001)

Power requirements	: DC 12 V (with the exclusive AC adaptor J46598 –001)
Audio input terminal	: 3.5 mm dia. stereo miniplug
Input impedance	: 30 kΩ
Reference input level	: 350 mV
Dimensions	: 137(W) x 147(D) x 123(H) mm (5-7/16" x 5-13/16" x 4-7/8") (including antenna)
Weight	: 200 g (7.1 oz) (Without connection cord and AC adaptor)

Headphones (HA-W250RF)

Power requirements	: Rechargeable Ni-Cd battery (1.2 V) x 2
Battery running time	: 6 hours (When charged for 24 hours)
Weight	: 220 g (7.7 oz) (With provided rechargeable Ni-Cd battery x 2)

Provided Accessories

Instructions	x 1
AC adaptor	x 1
Connection cord	x 1 (3.5 mm dia. stereo minijack — RCA pin plug x 2 : 0.1 m (0.3 ft))
Plug adaptor	x 1 (converts 3.5 mm dia. stereo miniplug to a 6.3 mm dia. standard stereo phone plug)

Exclusive rechargeable Ni-Cd battery x 2

** Design and specifications subject to change without notice.*

2.Disassembly

■ Transmitter

In case of some problems arise in this transmitter unit, have to change the transmitter unit itself, due to avoid the law of radio regulation.

■ Receiver(Headphones)

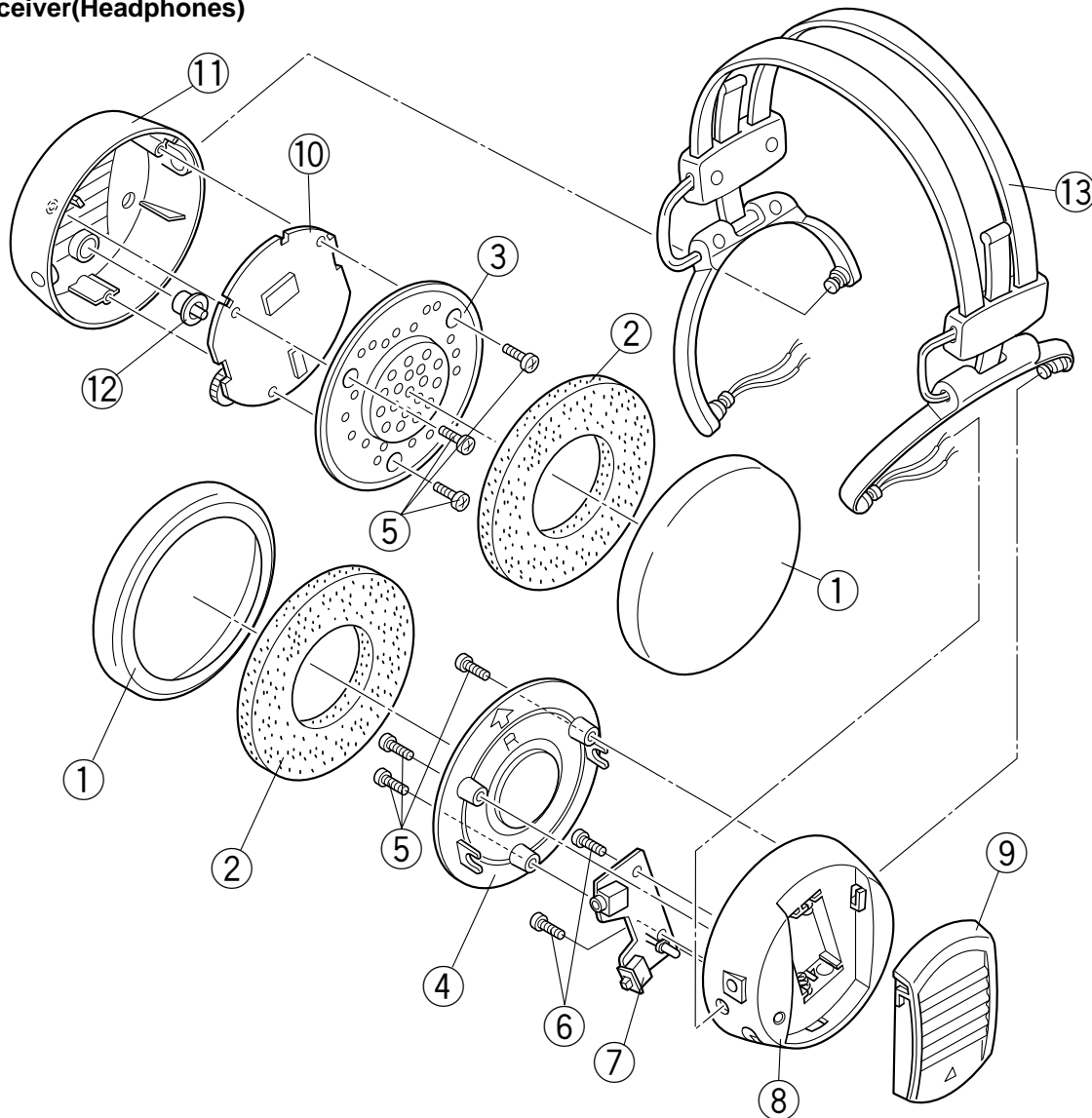

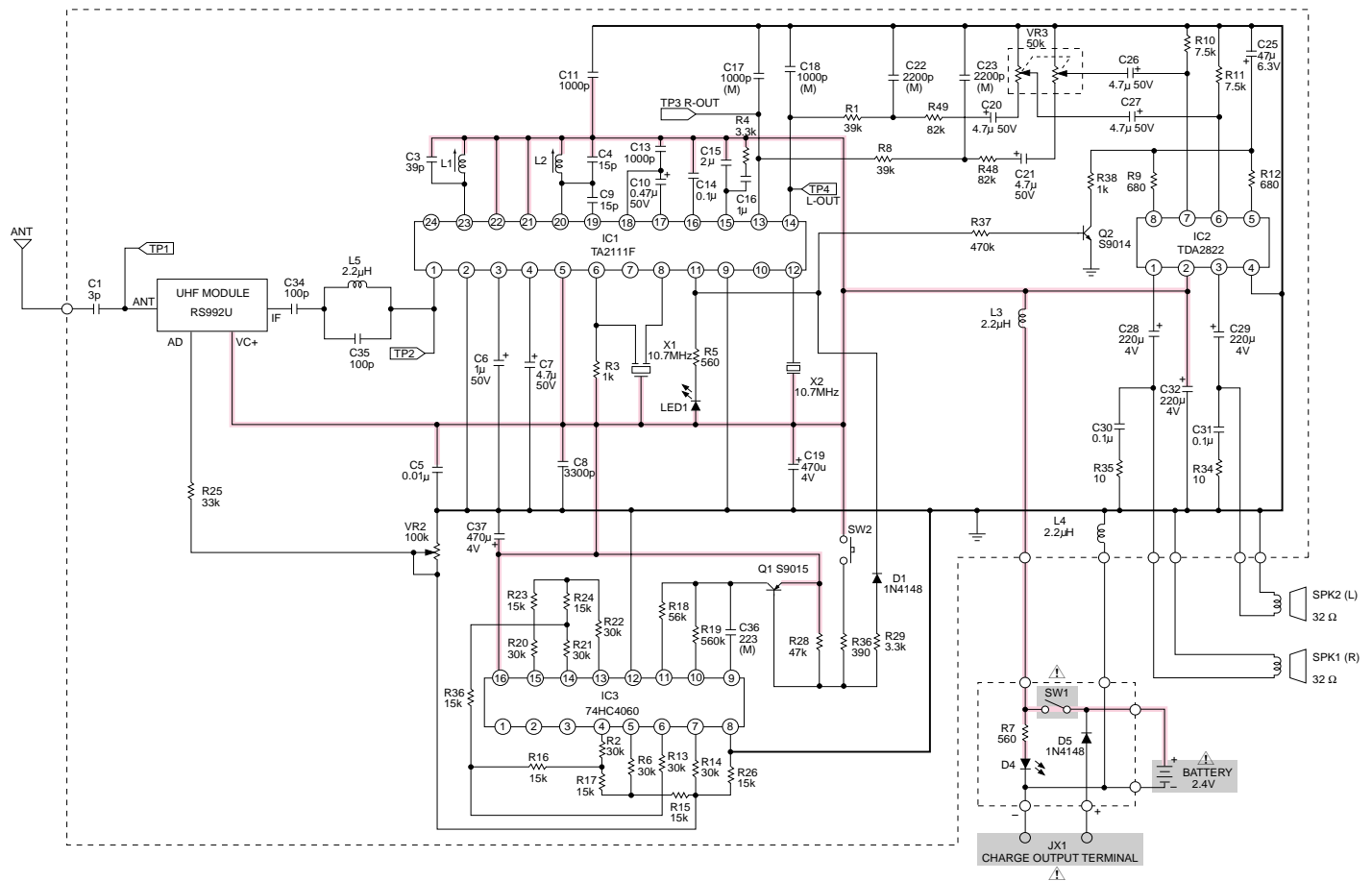

- 1.Remove the ear pad ① and the cushion ② from the driver unit ass'y (L) ③ and (R) ④.
- 2.Remove the screw ⑤ and pull up the driver unit ass'y(L) ③ and (R) ④.
- 3.At channel R. remove the screw ⑥ and pull up the charge print circuit board ⑦.
- 4.Remove the battery door ⑨ from the housing ass'y (R) ⑧.
- 5.At channel L. Remove the main print circuit board ⑩ from the housing (L) ⑪.
- 6.Remove the tuning switch knob ⑫.
- 7.Remove the wire with solder from the charge and main print circuit board ⑦⑩, then remove the headband ass'y ⑬.

3.Schematic Diagram



— Use of Circuit Diagram —

Notes:

1. The thick line (—) is the B (+) power supply.
2. This circuit diagram is the reference diagram. Circuits and constants are subject to change without notice for improvement.
3. Values printed in red show the voltages of each section measured by the tester (internal resistance 20 kOhms/V), with the power switch ON.
4. Parts marked with  (in the shaded area ) are safety parts. When replacing these, be sure to use only the designated parts to ensure safety.

4.Measurement Condition

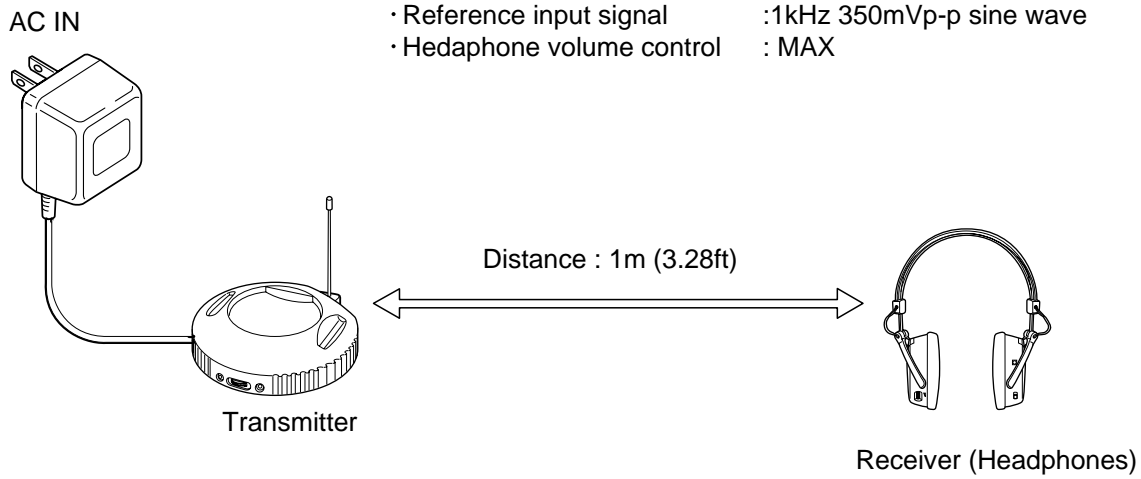

5.Print Circuit Board

■ Receiver (Headphones)
CHARGE P. C. BOARD

shows the B(+) power supply
shows the ground
shows others.

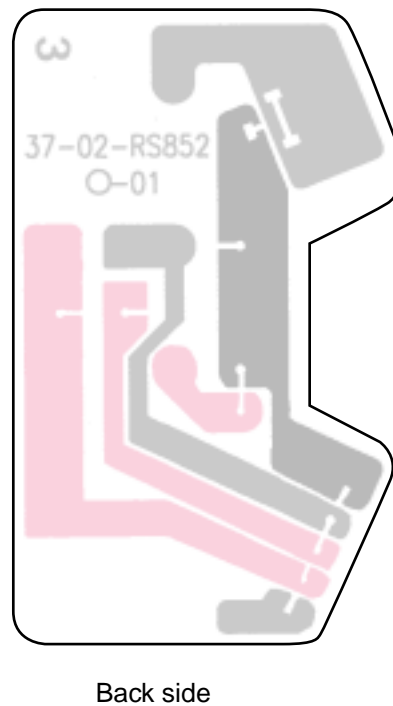
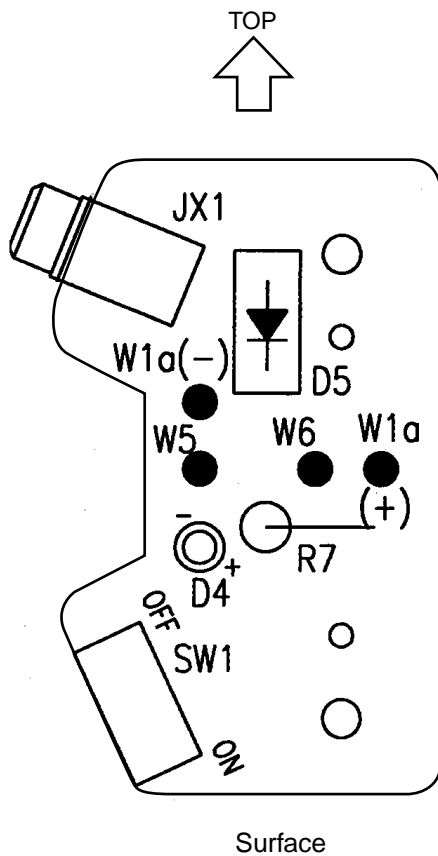

5. Print Circuit Board

Receiver (Headphones)

MAIN P. C. BOARD

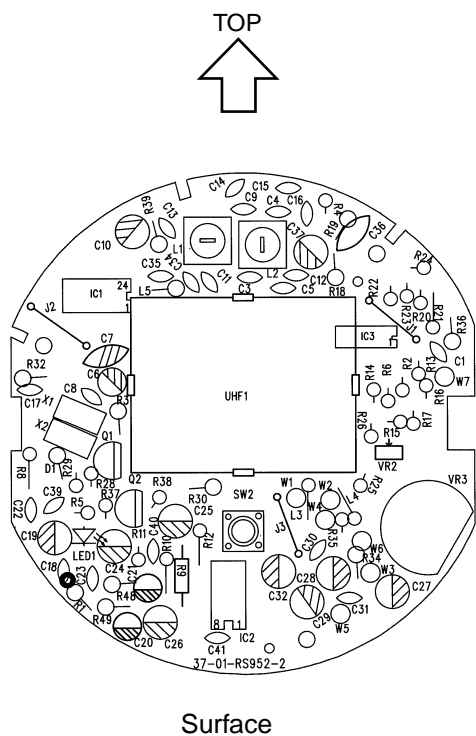

shows the B(+) power supply
 shows the ground
 shows others.

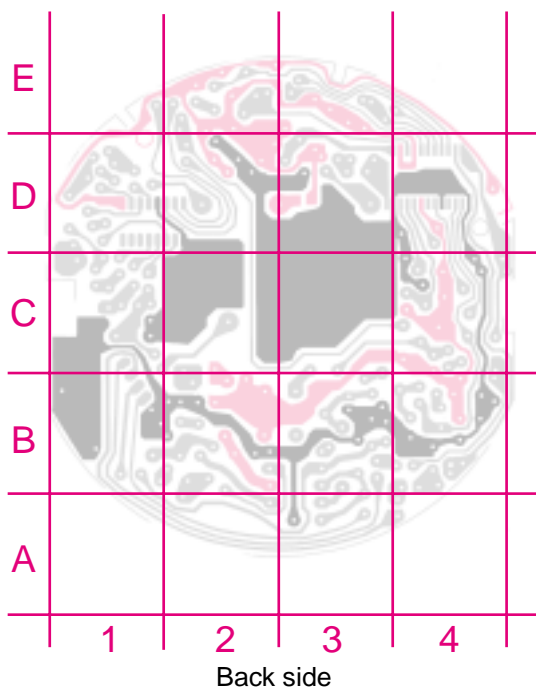

Receiver (Headphones)

MAIN P. C. BOARD Location

Symbol No	Location	Symbol No	Location	Symbol No	Location	Symbol No	Location
Module		Resistors		Resistors		Capacitors	
RS922u	3C	R9	3B	R39	3E	C21	3B
ICs		R10	3B	R48	4B	C22	4B
IC1	4D	R11	3B	R49	4B	C23	4B
IC2	3B	R12	3B	J1	1D	C25	3B
IC3	1D	R13	1C	J2	4D	C26	3A
Transistors		R14	1C	J3	2B	C27	1B
Q1	4C	R15	1C	Capacitors		C28	2B
Q2	3B	R16	1C	C1	1D	C29	2B
Filters		R17	1C	C3	2D	C30	2B
X2	4C	R18	2D	C4	2E	C31	2B
Piezoelectric cer. vibrators		R19	2D	C5	2D	C32	2B
X1	4C	R20	1D	C6	4D	C34	3D
Diodes		R21	1D	C7	4D	C35	3D
D1	4C	R22	1D	C8	4C	C36	2E
LED1	4B	R23	1D	C9	2E	C37	2D
Resistors		R24	1D	C10	3E	C39	4B
VR2	1C	R25	1C	C11	3D	Coils	
VR3	1B	R26	1C	C12	2D	L1	3E
R1	4B	R28	4C	C13	3E	L2	2E
R2	1C	R29	4C	C14	3E	L3	2B
R3	4C	R30	3B	C15	2E	L4	2B
R4	2E	R34	2B	C16	2E	L5	3D
R5	4B	R35	2B	C17	4C	Switch	
R6	1C	R36	1D	C18	4B	SW2	2B
R8	4C	R37	4B	C19	4B		
		R38	3B	C20	3A		

6.Wiring Diagram

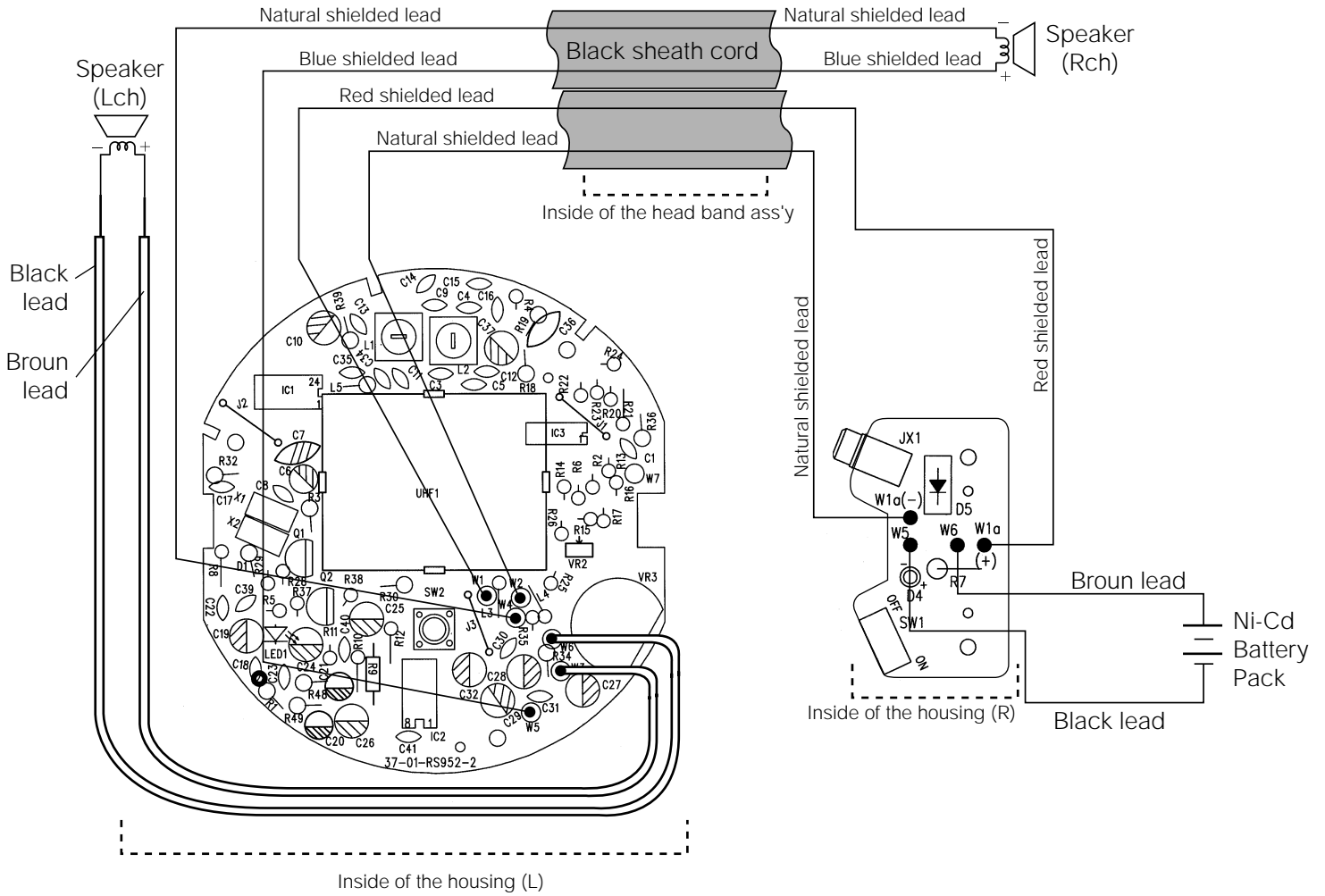

7.Block View Inside IC

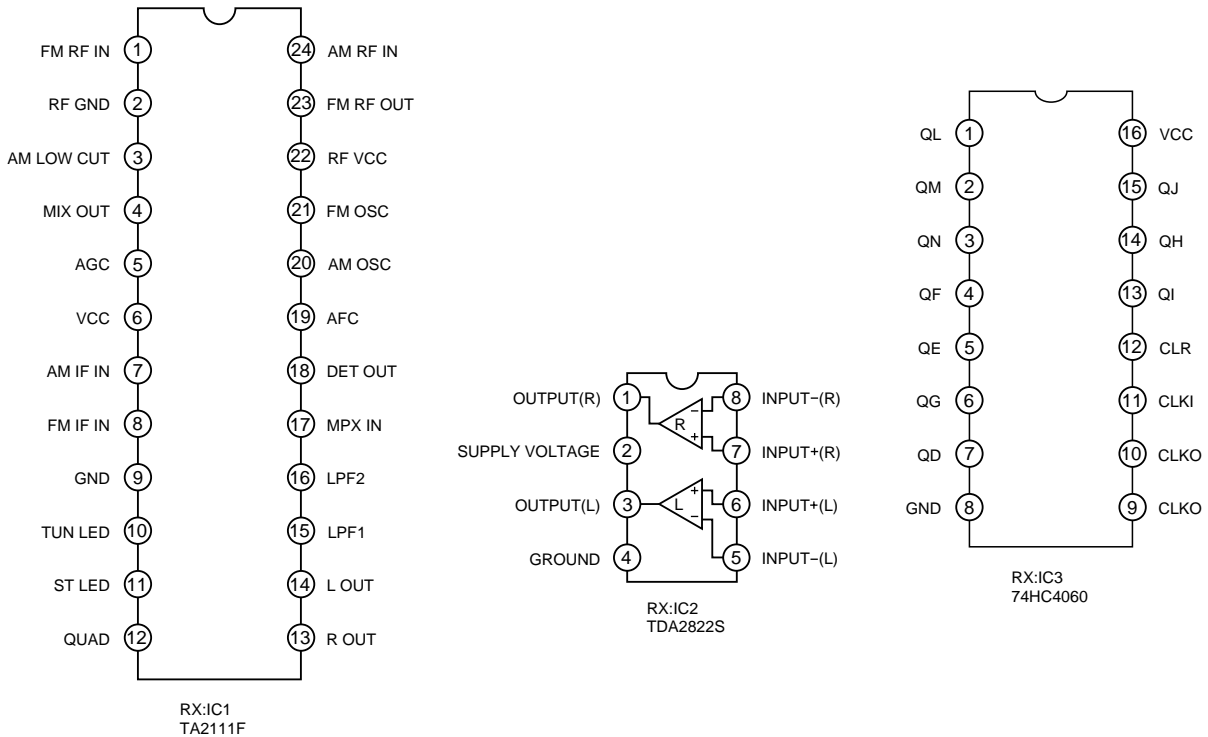

8. Block Diagram

Receiver (Headphones)

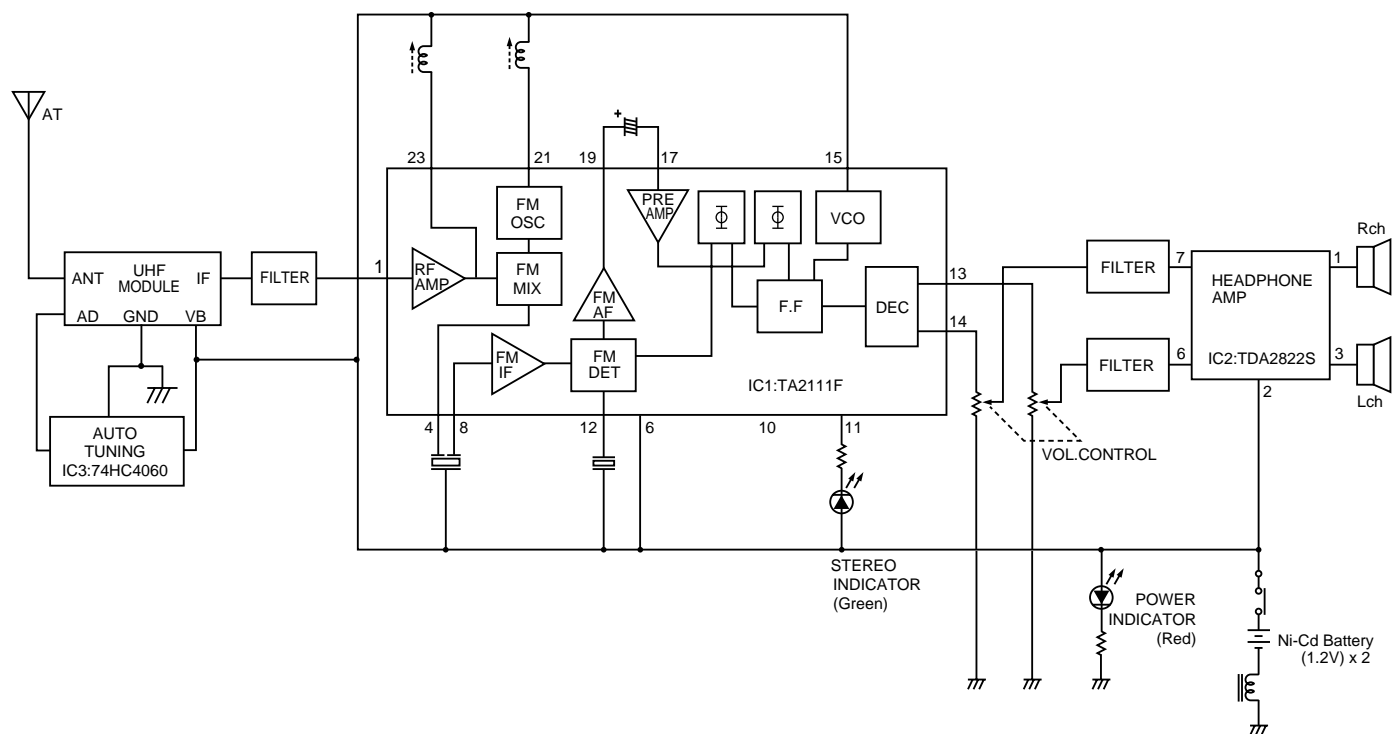

9. Electric Parts List

Transmitter

⚠	No.	Parts No.	Parts Name	Description
		J21967-001	Transmitter Unit	

In case of some problem arise in this transmitter unit, have to change the transmitter unit itself, due to avoid the law of radio regulation.

※Parts marked (⚠) are safety parts. When replacing, be sure to use the specified one.

Receiver (Headphones)

⚠	No.	Parts No.	Parts Name	Description
⚠		J33525-001	Main P.C.B Ass'y	Adjusted
		J46881-001	Charge P.C.B Ass'y	
	D2	J46882-001	LED	Stereo indicator
	D4	J46520-001	LED	Power indicator
	VR3	J46885-001	Variable Resistor	Volume control, 50kΩ X 2
⚠	SW1	J46883-001	Power Switch	Slide
	SW2	J46886-001	Tuning Switch	Tact
⚠	JX1	J46884-001	Charge Jack	

※Parts marked (⚠) are safety parts. When replacing, be sure to use the specified one.

10.Exploded View

■ Receiver(Headphones)

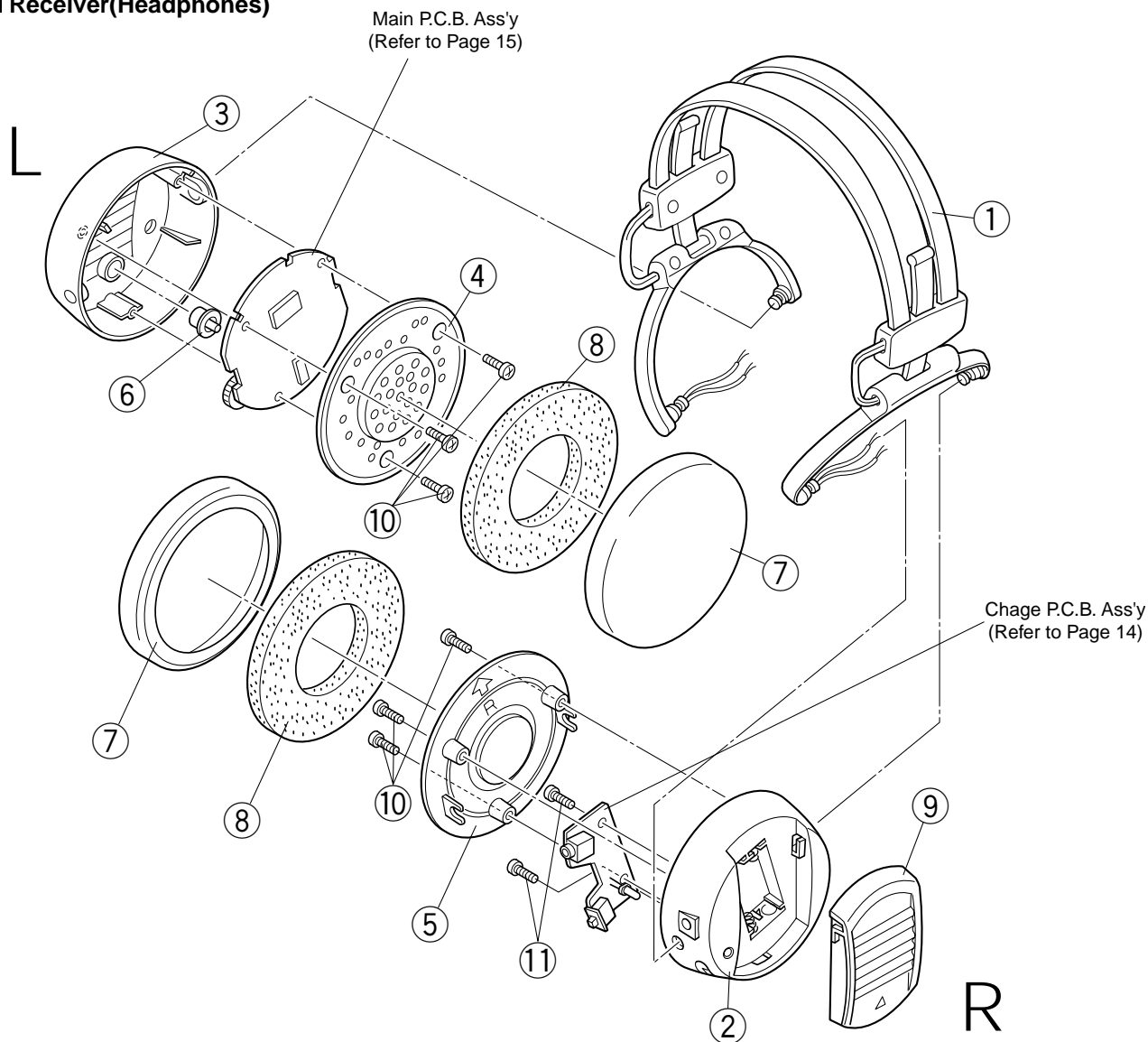

11.Mechanical Parts List

■ Receiver(Headphones)

⚠	Item No.	Parts No.	Parts Name	Q'ty	Description
	1	J21975-001	Headband Ass'y	1	with connecting wire
	2	J21958-002	Housing(R) Ass'y	1	with battery terminal
	3	J21957-002	Housing(L)	1	
	4	J33528-001	Driver Unit Ass'y(L)	1	with bottom cover
	5	J33529-001	Driver Unit Ass'y(R)	1	with bottom cover
	6	J33527-002	Tuning Switch Knob	1	
	7	J33530-001	Ear Pad	2	
	8	J33531-001	Cushion	2	
	9	J21959-002	Battery Door	1	
	10	QYSPSF2008	Screw	6	
	11	SPSG2005M	Screw	2	

※ Parts marked (⚠) are safety parts. When replacing, be sure to use the specific one.

12.Packing Method

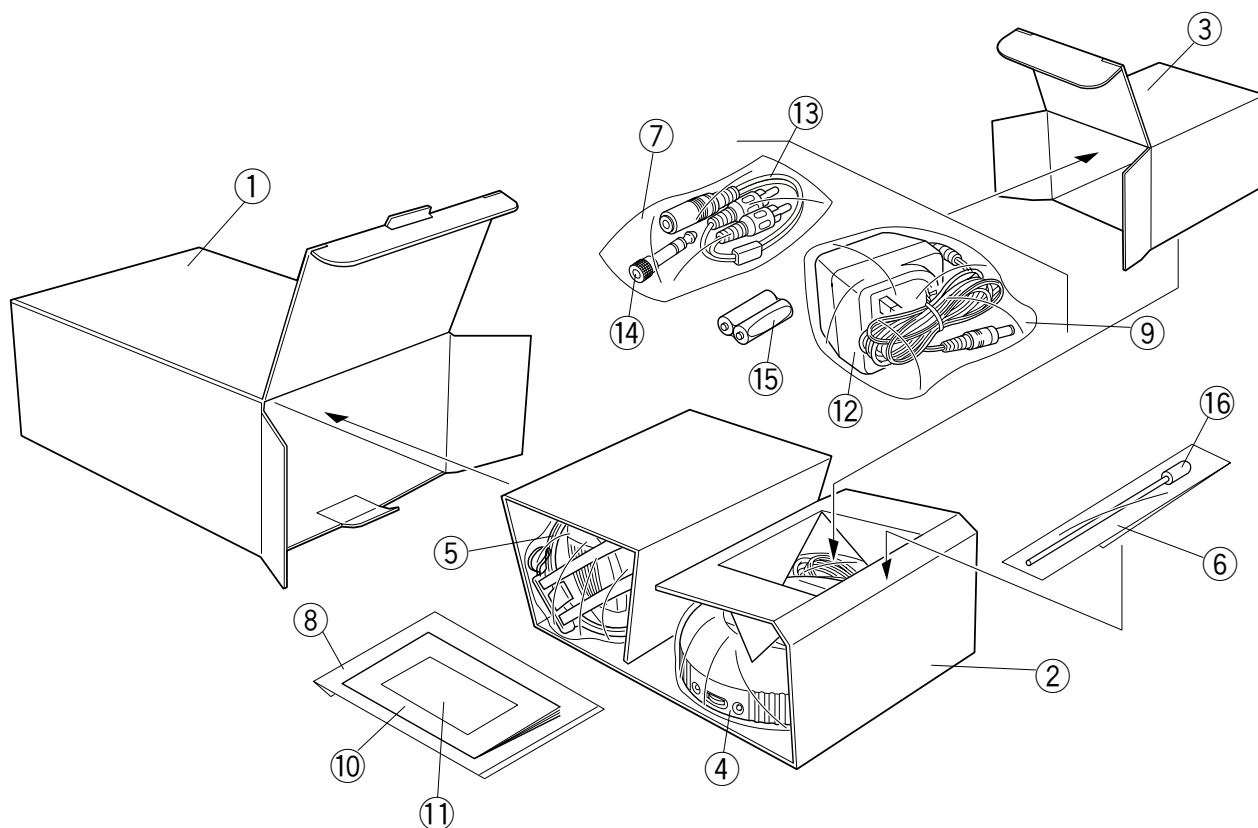

13.Packing Materials Parts List

⚠	Item No.	Parts No.	Parts Name	Q'ty	Description
	1	J21968-001	Packing case	1	
	2	J33532-001	Packing Holder	1	
	3	J33533-001	Sub Packing Holder	1	
⚠	4	QPC02504515P	Poly Bag	1	for transmitter
⚠	5	QPC02504515P	Poly Bag	1	for receiver(headphones)
	6	QPA00503005	Poly Bag	1	for antenna cover
	7	QPA00503005	Poly Bag	1	for connection cord
⚠	8	QPA01702505P	Poly Bag	1	for instructions and warranty information card
	9	QPA01502005	Poly Bag	1	for AC Adaptor

※ Parts marked (⚠) are safety parts. When replacing, be sure to use the specific one.

14.Accessories List

⚠	Item No.	Parts No.	Parts Name	Q'ty	Description
⚠	10	J5500-100A	Instructions	1	
	11	BT-51007-5	Warranty Information Card	1	
⚠	12	J46598-001	AC Adaptor	1	
	13	J33534-001	Connection cord	1	
	14	J46517-001	Plug adaptor	1	
	15	J46863-001	Rechargeable Ni-Cd batteries	1	2pcs/pack
	16	J46887-001	Antenna cover	1	

※ Parts marked (⚠) are safety parts. When replacing, be sure to use the specific one.

JVC

VICTOR COMPANY OF JAPAN, LIMITED

COMMUNICATION NETWORK BUSINESS UNIT, 1644, SHIMOTSURUMA, YAMATO-SHI, KANAGAWA-KEN, 242-8514, JAPAN